

# KBAS122500 12V 250Ah



The Kaise Solar range is mainly used in the renewable energies industry, given their optimal performance in cyclic use. With lower acid density, excess of electrolyte and larger distance between plates the batteries maintain a low temperature and also slows down the plate grid corrosion speed. These batteries have a unique plate grid configuration which, alongside the high quality AGM separator and the battery management system, ensures the batteries have a longer service life. The valves were specially designed to control water loss and prevent air and other elements from getting in.

## Performance Characteristics

Nominal Voltage	12V	
Dimensions	Length (mm / inch)	522 / 20.55
	Width (mm / inch)	240 / 9.45
	Height (mm / inch)	218 / 8.58
	Total Height (mm / inch)	224 / 8.81
Approx. Weight	(Kg / lbs) 57.4 / 126.6	
Design Life	8 - 12 years	
Terminal	M8	
Container Material	ABS	
Rated Capacity	250.0 Ah / 2.50 A	(100hr, 1.80V/cell, 25°C / 77°F)
	208.0 Ah / 10.4 A	(20hr, 1.80V/cell, 25°C / 77°F)
	200.0 Ah / 20.0 A	(10hr, 1.80V/cell, 25°C / 77°F)
	172.5 Ah / 34.5 A	(5hr, 1.75V/cell, 25°C / 77°F)
	122.0 Ah / 122.0 A	(1hr, 1.60V/cell, 25°C / 77°F)
Max. Discharge Current	2000A (5s)	
Internal Resistance	Approx 2.7mΩ	
Operating Temp. Range	Discharge : -15 ~ 50°C (5 ~ 122°F)	
	Charge : 0 ~ 40°C (32 ~ 104°F)	
	Storage : -15 ~ 40°C (5 ~ 104°F)	
Nominal Operating Temp. Range	25 ± 3°C (77 ± 5°F)	
Cycle Use	Initial Charging Current less than 50.0A	
	Voltage: 14.4V ~ 15.0V at 25°C (77°F)	
	Temp. Coefficient: -30mV/°C	
Standby Use	Initial Charging Current less than 50.0A	
	Voltage: 13.5V ~ 13.8V at 25°C (77°F)	
	Temp. Coefficient: -20mV/°C	
Capacity affected by Temperature	40°C (104°F)	103%
	25°C (77°F)	100%
	0°C (32°F)	86%
Self Discharge	Fully charged Kaise Solar Series batteries may be stored for up to 6 months at 25°C (77°F) and then a freshening charge is required. For higher temperatures the time interval will be shorter.	

## Constant Current Discharge (Amperes) at 77°F (25°C)

Volts/cell	15min	30min	45min	1h	5h	10h	20h	100h
1.80V	282.4	179.5	133.9	105.6	33.6	20.0	10.4	2.50
1.75V	302.0	189.2	139.0	110.5	34.5	20.2	10.5	2.52
1.70V	322.5	196.4	144.5	114.0	35.3	20.4	10.7	2.55
1.65V	342.9	204.6	148.1	117.8	36.3	20.8	10.8	2.59
1.60V	366.7	216.0	154.4	122.0	37.3	21.0	10.9	2.61

## Dimensions and Terminal (Unit: mm (inches))

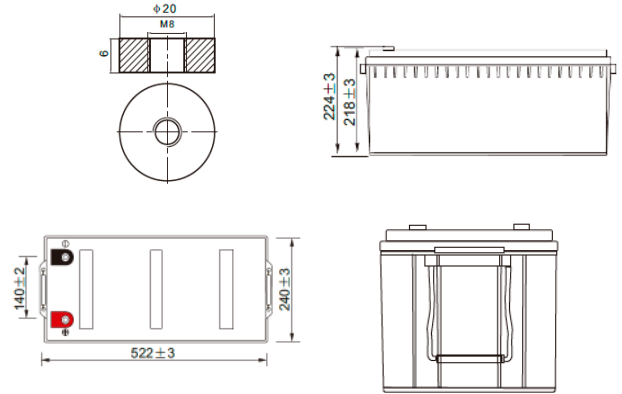

## Applications

- Renewable Energy
- Alarm systems
- Electric Test Equipment
- Emergency lighting systems
- Marine equipment
- Telecommunications systems

## Certifications

ISO 9001:2008 ISO 14001:2008



## Discharge Current vs. Discharge Voltage

Final discharge voltage V/CELL	1.8	1.75	1.7	1.6
Discharge current (A)	I ≤ 0.1CA	0.25CA ≥ I > 0.1CA	0.55CA ≥ I > 0.25CA	I > 0.55CA

## Constant Power Discharge (Watts per cell) at 77°F (25°C)

Volts/cell	15min	30min	45min	1h	5h	10h	20h
1.80V	519.9	336.9	255.4	202.6	65.5	39.5	20.6
1.75V	549.2	352.2	262.5	211.0	67.2	39.9	20.7
1.70V	578.2	363.5	272.0	217.0	68.6	40.2	21.1
1.65V	610.1	375.7	276.3	222.7	70.2	41.0	21.4
1.60V	641.7	393.8	286.4	229.4	72.0	41.4	21.5

(Note) The above characteristics data are average values obtained within three charge/discharge cycles not the minimum values.

## Charging Characteristic (float use)

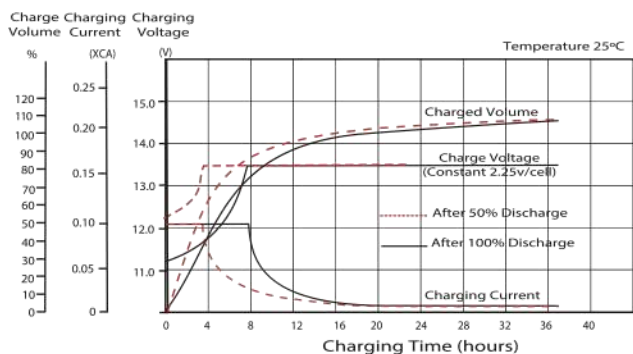

## Cycle Life in Relation to Depth of Discharge

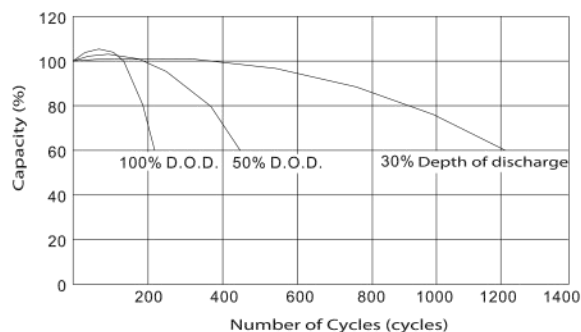

## Temperature Effects in Relation to Battery Capacity

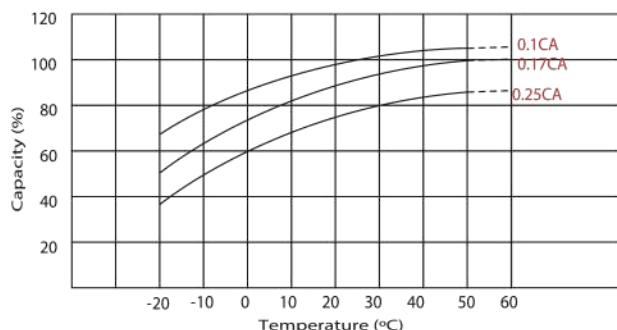

## Effect of Temperature on Long Term Float Life

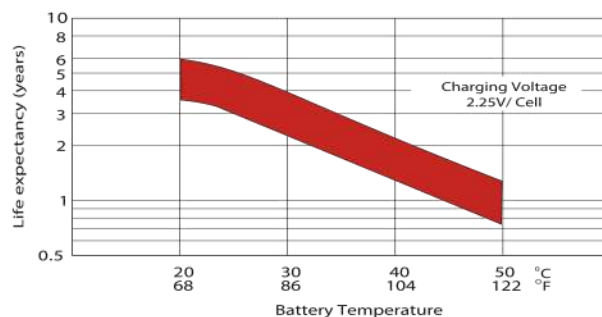

## Self Discharge Characteristics

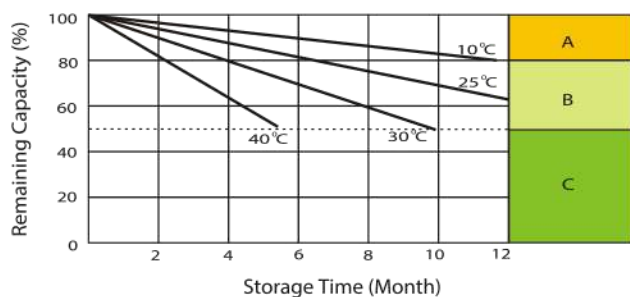

- A** With switch regulator (two-step controller) charge on curve max. charge voltage for max. 2 hrs/ day then switch over to continuous charge.
- B** Standard charge without switching.
- C** Boost charge (Equalizing charge with external generator) charge on curve continuous charge for max. 5 hrs/month, then switch over to curve Standard charge.

IMPORTANT NOTE: The specifications presented herein are subject to revision without notice.